

**172x150x51mm (6.77x5.90x2.01in) - 5 blade**

Bearing System— 2 Ball Bearing,  
 Life Expectancy--- Ball 50000hrs@ 25°C  
 Frame----- Aluminum  
 Impeller----- Thermoplastic PBT+15% GF, UL94V-0  
 Lead Wire----- UL 1015, AWG 22, 300±10mm, Black  
 Protection----- Locked rotor protection  
 IP Grade ----- Optional

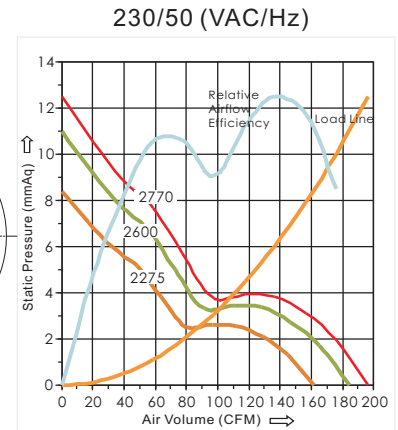
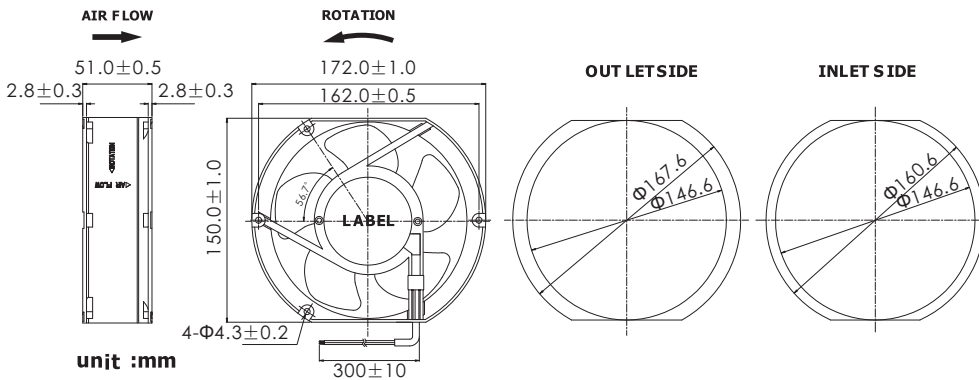
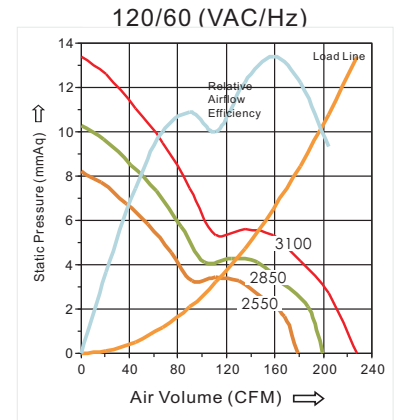

FUNCTIONS	PART NUMBER	VOLTAGE/RANGE (VAC)	LABEL CURRENT	ACTUAL CURRENT	POWER (WATTS)	SPEED (RPM)	AIRFLOW (CFM)(m³/min)	PRESSURE (mmAq)(In H²O)	NOISE (dBA)	WEIGHT (Q'TY/CTN)
Thermally Protected	PM1751HA1BAL-5		0.40	0.427	32.5	3100	227.5 6.44	13.4 0.52	48.6	950g (16pcs)
	PM1751MA1BAL-5	120/60	0.36	0.304	25.9	2850	199.5 5.65	10.3 0.40	45.5	
	PM1751LA1BAL-5	100~125	0.32	0.300	23.5	2550	178.5 5.05	8.20 0.32	42.0	
	PM1751HA2BAL-5		0.23	0.258	38.5	2770	196.5 5.56	12.5 0.48	44.5	
	PM1751MA2BAL-5	230/50	0.15	0.134	21.2	2600	184.4 5.22	11.0 0.42	42.5	
	PM1751LA2BAL-5	200~240	0.12	0.097	17.4	2275	161.4 4.57	8.40 0.32	39.5	

Dim: 570x440x195mm  
 N.W.: 15.2 kgs  
 G.W.: 16.8 kgs  
 Q'TY: 16 pcs



IATF 16949:2016  
 ISO 9001:2015  
 ISO 14001:2015