

120x120x25mm (4.72x4.72x0.98in) - 7 blade

Bearing System— 2 Ball Bearing,
 Life Expectancy--- Ball 50000hrs@ 25°C
 Frame----- Aluminum
 Impeller----- Thermoplastic PBT+15% GF, UL94V-0
 Lead Wire----- UL 1007, AWG 22, 300±10mm, Black
 Protection----- Locked rotor protection
 IP Grade ----- Optional

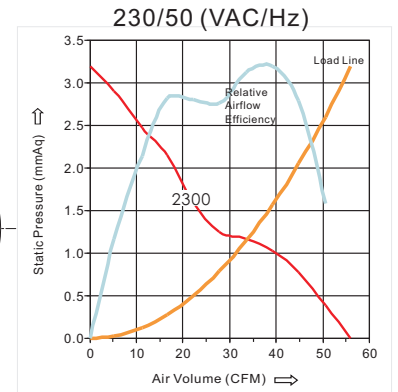
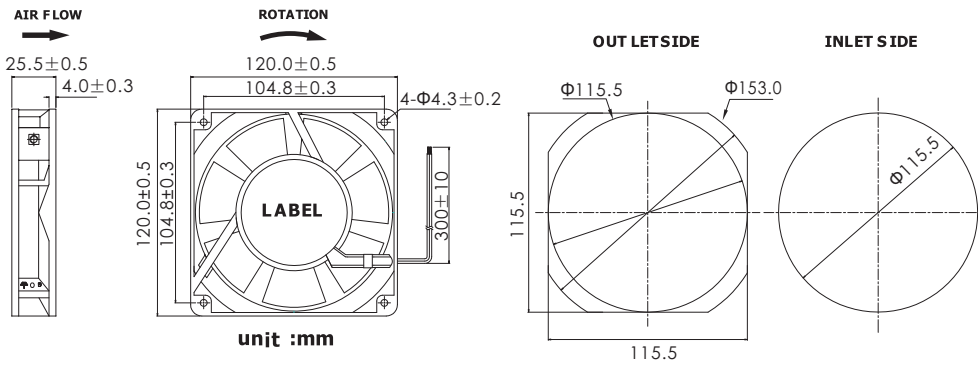
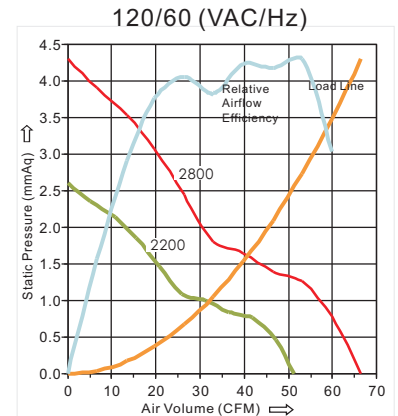

FUNCTIONS	PART NUMBER	VOLTAGE/RANGE (VAC)	LABEL CURRENT	ACTUAL CURRENT	POWER (WATTS)	SPEED (RPM)	AIRFLOW (CFM)(m³/min)	PRESSURE (mmAq)(In H²O)	NOISE (dBA)	WEIGHT (Q'TY/CTN)
	PM1225HA1BAL-7	120/60	0.15	0.122	15.5	2800	66.5 1.83	4.30 0.16	38.0	350g (40pcs)
	PM1225LA1BAL-7	100~125	0.08	0.062	6.50	2200	51.3 1.45	2.60 0.10	30.5	
	PM1225HA2BAL-7	230/50 200~240	0.08	0.050	15.6	2300	56.0 1.58	3.20 0.12	32.5	

Dim: 360x280x280mm
 N.W.: 14.0 kgs
 G.W.: 15.6 kgs
 Q'TY: 40 pcs



IATF16949:2016
 ISO 9001:2015
 ISO 14001:2015